



Accessories

10048509-Draw-Wire-WDS-3000-P96-M



General Data

Intro	Draw Wires or Cable Pull adapters when combined with encoders enable to measure the linear position accurately and also communicate the position over the interface of your choice. All POSITAL draw wire adapters use a stainless steel measuring wire
Flange Type	Synchro - Solid Shaft
Flange Diameter	58 mm
Accuracy	± 0.02 % FSO
Repeatability	± 0.003 % FSO
Measurement Length	3.00 m (9.84')
Draw Wire Enclosure	Draw Wire Enclosure#Extruded Metal
Draw Wire Housing Material	Aluminum
Wire Material	Coated Polyamide Stainless Steel
Wire Diameter	0.80 mm
Length per Revolution	260 mm
Max. Speed of Wire Displacement	2.0 m / s
Max Extension Force	9.0 N
Max. Angular Acceleration	7.0 g
Min Retraction Force	5.5 N
Wire Mounting	M4 Thread

Data Sheet

Printed at 13-06-2023 07:06



Shaft Diameter 6 mm

Max. Wire Exit Angle $\pm 3^\circ$

Mechanical Data

Operating Temperature -20°C to 80°C / -4°F to 176°F

Weight 800 g

2xFeststellschrauben M4
2xSetscrews M4

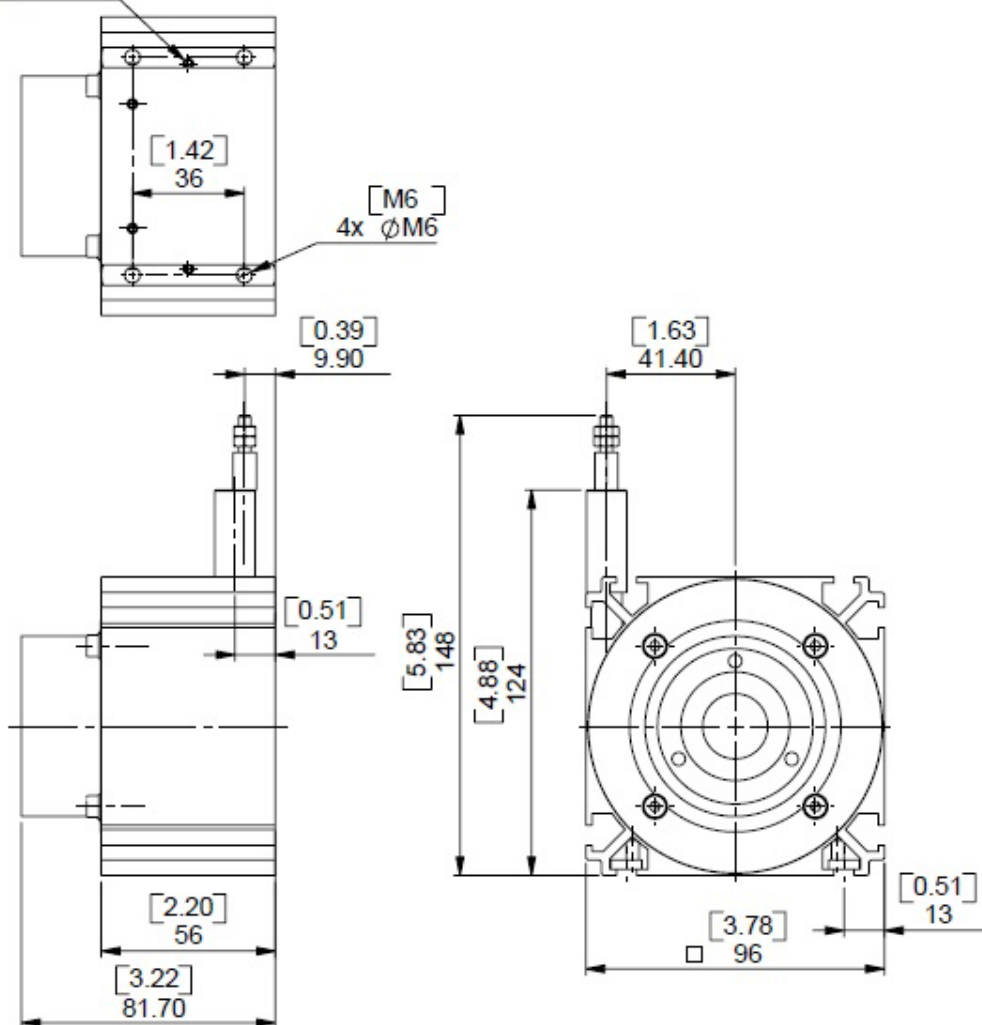

Contact



Contact Us

All dimension in [inch] mm. This drawing and the information contained is for general presentation purposes only. Please refer to the "Download" section for detailed technical drawings. © FRABA B.V., All rights reserved. We do not assume responsibility for technical inaccuracies or omissions. Specifications are subject to change without notice.