



RS425 Contactless Torque Transducer

Product Overview

V2.1

RS425 Contactless Torque Transducer

Product Overview

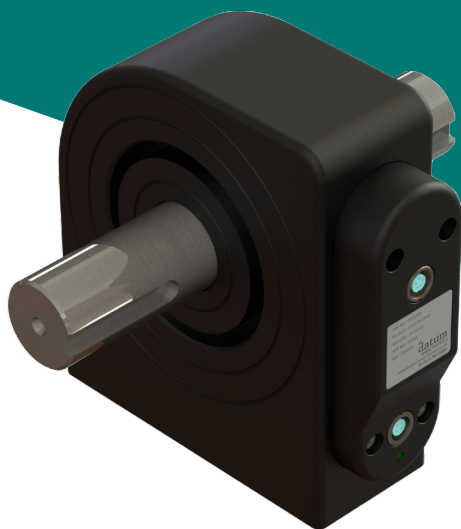

Performance and Benefits:

Lightweight Torque transducer with completely separate rotor and stator set

No mechanical friction, long-term operation reduced maintenance

Keyway shaft for easy fitting to test rigs and drive systems

Spline shafts are also available as an alternative to a keyway shaft

No bearings – ideal for high speed applications

Standard RS425 torque transducer range available from 0 to 30,000Nm

Standard IP Rating 54 - can be upgraded to IP68

Compatible with industry standard couplings supplied with DIN rail mountable Datum Connect Interface (DCI)

Contactless Torque Sensor with completely separate rotor and stator

The Datum Electronics RS425 Series contactless rotary torque transducers have been designed to fit easily in line with any drivetrain or test bed with its standard keyway shaft. The RS425 is a true contactless torque transducer, the rotor runs inside the stator with 2 to 5mm gap. This ensures no longterm wear of bearings or frictional loads on the rotating drive shaft.

The DC Torque Transducers are Wi-Fi enabled to communicate with the Datum Connect app (available on both Android and iOS and Windows) and have been designed to fit with most applications and solutions requiring rotary torque measurement.

We are able to modify the shaft configuration of the transducer to best suit your requirements, and can even design bespoke ends to fit including splines and smooth shafts for example.. This type of transducer has many advantages over other torque systems including: zero bearing friction, high speed and high torque applications.

RS425 System Advantages:

Accurate On Shaft Torque Measurement

Modular System Assembly

Contactless Transmission

Proven Technology

Low Maintenance

Linear Calibration

Rotary and Static Torque Measurement

Calibrated analogue data for torque speed and power

Custom configurations available

Environment	
Thermal Stability of Gain per 10°C	0.02%
Thermal Stability of Zero per 10°C	0.02%
Normal Specification Range	10 to 60°C
Operating Range	-10 to +70°C
Storage Range	-35 to +75°C
Electromagnetic Compatibility	EN61326-1:2006 (IEC61000-4), IEC60945)

Contact our technical sales team or sales team to discuss:

web@datum-electronics.co.uk / +44(0)1983 282834

datum-electronics.com



RS425 Contactless Torque Transducer

Product Overview



The RS425 Torque Sensor Range

The RS425 torque transducer utilises a strain gauged shaft for accurate and reliable torque measurement and a set of rotating on shaft conditioning electronics, the digital signals are transmitted to the non-rotating part of the system or stator providing a reliable and highly accurate torque measurement solution. The rotor is continuously powered enabling static torque measurement to be made. Not only does the RS425 Series offer great technical advantages but the range of torque sensors are competitively priced.

The RS425 series torque transducer is not limited by bearings; therefore, it can be used at higher speeds, and places no bearings loads on to the shaft. The stator needs to be mounted in relation to the shaft within an operating envelope of +/- 3 to 5mm. The standard range can measure torque ranges from 0 to 30,000Nm, the same modular elements have been applied to bespoke torque transducers for use down as low as 3Nm and up to 500kNm and above.

Using our new generation of electronics as found in our industry standard M425 Torque transducer, RS425 Connect Torque Transducers are Wi-Fi enabled to

communicate with the Datum Connect app (available on both Android and iOS and Windows).

The high-tech non-contact communication system provides data directly proportional to torque, offering a comprehensive range of available digital and analogue outputs.

With its frictionless system the RS425 can achieve higher speeds than listed as standard. With speeds of up to 30,000rpm being possible, please discuss with Datum Sales about your application.

The Competitive Edge

The Series RS425 transmits calibrated digital data as this is a cleaner and more defined method of transmitting data. The on-shaft signal from the strain gauge is converted to a digital signal and amplified on shaft. With Datum Connect Electronics this allows your smart phone/device to act as both display and data logger and with our Datum Connect Interface [DCI].

Contact our technical sales team or sales team to discuss:

web@datum-electronics.co.uk / +44(0)1983 282834

datum-electronics.com



RS425 Contactless Torque Transducer

Product Overview



Performance Characteristics

RS425 Model Size	Rated load (Nm)	Rated load (lb ft)	Standard Rotational speed (RPM)*	*Stator mass (Kgs)	Rotor mass (Kgs)
Size 1 - AL	0-3	7.7	10,000	1.057	0.401
Size 1 - A	0-10	7.4	10,000	1.057	0.401
Size 1 - B	0-20	14.8	10,000	1.057	0.421
Size 1 - C	0-50	36.9	10,000	1.057	0.462
Size 1 - D	0-100	73.8	10,000	1.057	0.560
Size 2 - A	0-250	184	10,000	1.057	1.201
Size 2 - B	0-500	369	10,000	1.057	1.276
Size 3 - A	0-1,000	738	6,000	1.057	1.668
Size 3 - B	0-2,000	1,475.1	6,000	1.057	2.149
Size 4 - A	0-5000	3,687.9	5,000	1.152	6.112
Size 4 - B	0-10,000	7,375.7	5,000	1.152	12.162
Size 5 - A	0-15,000	11,064	2,000	2.138	20.499
Size 5 - B	0-20,000	14,751	2,000	2.138	22.318
Size 5 - C	0-25,000	18,439	2,000	2.138	34.608
Size 5 - D	0-30,000	22,127	2,000	2.138	40.969



Contact our technical sales team or sales team to discuss:

web@datum-electronics.co.uk / +44(0)1983 282834

datum-electronics.com



RS425 Contactless Torque Transducer

Product Overview



Tech Specifications

	A	B	C	D	E	F	G	H	I	J	K	L	M
FF425 Model Size	Shaft length face to face (mm)	Body width (mm)	Shaft Ø g6 TOL (ISO 286-2)	Keyway length (BS 4235-1 : 1972)	Keyway width (BS 4235-1 : 1972)	Output module length (mm)	Output module height (mm)	Keyway depth off axial centre (BS 4235-1 : 1972)	Base to shaft axial centre (mm)	Overall height (mm)	Base length (mm)	Base fixing holes. Centre to centre (mm)	Fixing holes (DIN 933)
Size 1 - A	150	50	15	22.5	5	112	8.5	4.3	80	140	120	100	M8
Size 1 - B	150	50	15	22.5	5	112	8.5	4.3	80	140	120	100	M8
Size 1 - C	150	50	15	22.5	5	112	8.5	4.3	80	140	120	100	M8
Size 1 - D	150	50	15	22.5	5	112	8.5	4.3	80	140	120	100	M8
Size 2 - A	170	50	30	44	8	112	8.5	11	80	140	120	100	M8
Size 2 - B	170	50	30	44	8	112	8.5	11	80	140	120	100	M8
Size 3 - A	240	50	50	78.5	12	112	8.5	20	80	140	120	100	M8
Size 3 - B	240	50	50	78.5	12	112	8.5	20	80	140	120	100	M8
Size 4 - A	240	50	75	78.5	20	112	8.5	30	80	140	120	100	M8
Size 4 - B	240	50	75	78.5	20	112	8.5	30	80	140	120	100	M8
Size 5 - A	292	60	110	116	32	112	8.5	44	120	220	200	180	M10
Size 5 - B	292	60	110	116	32	112	8.5	44	120	220	200	180	M10
Size 5 - C	292	60	110	116	32	112	8.5	44	120	220	200	180	M10
Size 5 - D	292	60	110	116	32	112	8.5	44	120	220	200	180	M10

Alphabet Key for RS425 Model Sizes 1 to 5

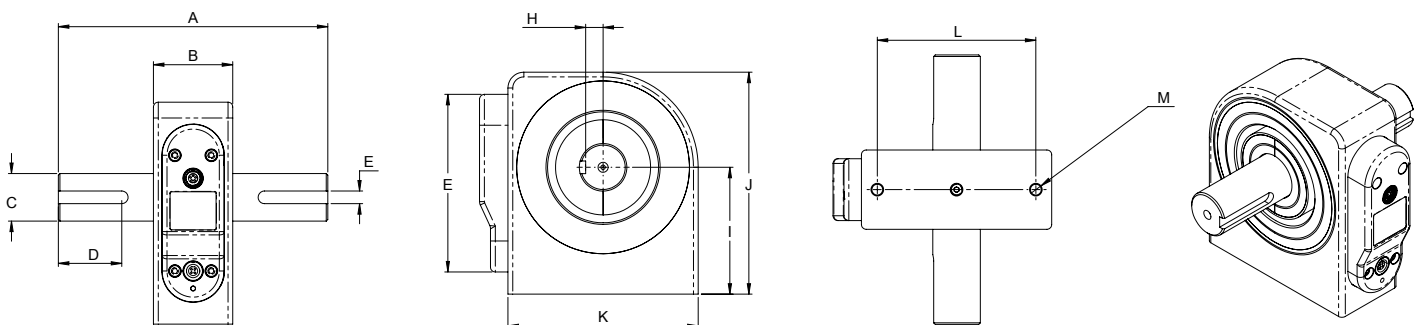

3D models and STEP files are available from Datum Electronics to assist project planning. Please contact Datum Electronics for more information.

*For higher speed requirements please discuss your requirements with our sales team
This drawing and its associated design is the property of Datum Electronics Ltd. and may not be copied or used for any purpose other than that for which it is supplied, without the express written authority from Datum Electronics Ltd.

Contact our technical sales team or sales team to discuss:

web@datum-electronics.co.uk / +44(0)1983 282834

datum-electronics.com





datum
electronics



Contact Datum to discuss your needs on:
web@datum-electronics.co.uk • +44(0)1983 282834

datum-electronics.com

