

Technical data sheet

227CZ-024-15-S1/RE20 Rotary actuator

Description

Rotary actuator for adjusting dampers in HVAC installations

- Running time 100 s / 90°
- Torque 15 Nm
- Nominal voltage 24 VAC/DC
- Control continuous control (0)2...10 VDC
- Auxiliary switch 1x freely adjustable
- Damper size up to approx. 3 m²
- Shaft coupling clamp
∅ 8-14 mm / Ø 8-20 mm



Technical data

Electrical data	Nominal voltage	24 VAC/DC, 50/60 Hz
	Nominal voltage range	19...29 VAC/DC
	Power consumption motor (motion)	2,0 W
	Power consumption standby (end position)	1,0 W
	Wire sizing	3,5 VA
	Control	continuous control (0)2...10 VDC / Ri > (100 kΩ) 50 kΩ (0)4...20 mA / Rext. = 500 Ω
	Feedback signal	(0)2...10 VDC, max. 5 mA
	Auxiliary switch	1x SPDT (Ag)
	Contact load	5 (2,5) A, 250 VAC
	Switching point	0...95°
	Connection motor	cable 1000 mm, 4 x 0,75 mm ² (halogen free)
	Connection feedback potentiometer	-
	Connection auxiliary switch	cable 1000 mm, 3 x 0,75 mm ² (halogen free)

Technical data

Electrical data	Connection GUAC	-	
Functional data	Torque	15 Nm	
	Damper size	up to approx. 3 m ²	
	Synchronised speed	±5%	
	Direction of rotation	selected by switch	
	Manual override	gearing latch disengaged with pushbutton, self-resetting	
	Angle of rotation	0°...max. 95° can be limited with adjustable mechanical end stops after changing the angle of rotation, a adaptation drive must be made	
	Running time	100 s / 90°	
	Sound power level	< 35 dB(A)	
	Shaft coupling	clamp ∅ 8-15 mm / ∅ 8-20 mm	
	Position indication	mechanical with pointer	
	Service life	> 60 000 cycles (0°...95°...0°) > 1 000 000 partial cycles (max. ±5°)	
	Safety	Protection class	(safety extra-low voltage)
		Degree of protection	IP 54 (cable downwards)
EMC		CE (2014/30/EU)	
LVD		CE (2014/35/EU)	
RoHS		CE (2011/65/EU - 2015/863/EU - 2017/2102/EU)	
Mode of operation		Typ 1 (EN 60730-1)	
Rated impulse voltage		0,8 kV (EN 60730-1)	
Control pollution degree		3 (EN 60730-1)	
Ambient temperature normal operation		-30°C...+50°C	
Storage temperature		-30°C...+80°C	
Ambient humidity		5...95% r.H., non condensing (EN 60730-1)	
Maintenance	maintenance free		
Dimensions / Weight	Dimensions	147 x 65 x 61 mm	
	Weight	500 g	

Functionality / Properties

Operating mode

Connect power supply to wire 1+2 and a reference signal Y to wire 3 in range of (0)2...10 VDC, actuator drives to its specified position. The actual damper position (0...100%) is a feedback signal U on wire 4 for example to share with other actuators.

The actuator is overload-proof, requires no limit switches and automatically stops, when the end stop is reached.

Direct mounting

Simple direct mounting on the damper shaft with a clamp, protection against rotating with enclosed anti-rotation lock or rather at intended attachment points.

Manual override

Manual override with self-resetting pushbutton possible (the gear is disengaged as long as the button is pressed).

Signaling

The integrated auxiliary switch is freely adjustable in the angle of 0 - 95°. There is activated corresponding to the adjusted angle. The damper position can be checked by the mechanical pointer.

Mode switch

Mode switch with five positions at the housing:

- 2-10 R: rotary direction right 2-10 VDC
- 0-10 R: rotary direction right 0-10 VDC
- Adp: adaption
- 0-10 L: rotary direction left 0-10 VDC
- 2-10 L: rotary direction left 2-10 VDC

Adaption drive

- Actuator power off
- Setting the mechanical end stops
- Actuator power on
- Adaption enable
- Actuator drive to position 0
- Actuator drive to position 1
- Adaption disable, if desired angular range reached or rather if actuator reached endstop
- "Y" refers to the measured angular range

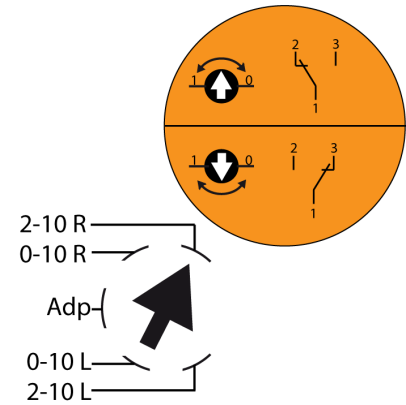

Connector / Security Note

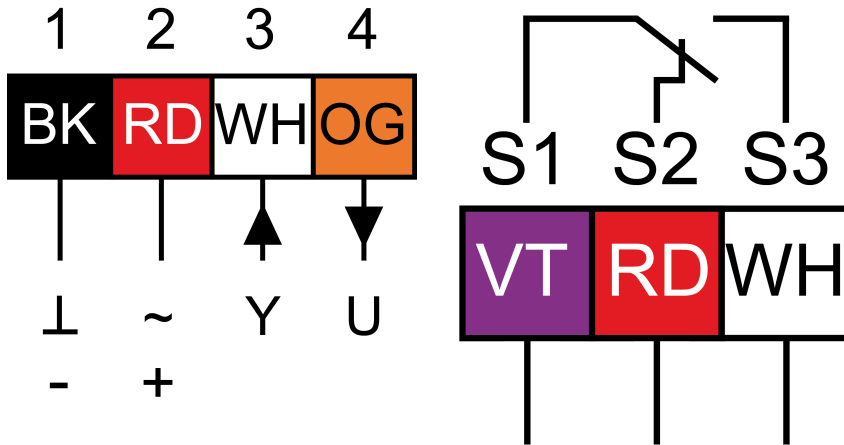

Safety remarks

- Connect via safety isolation transformer!
- The device is not allowed to be used outside the specified field of application, especially in airplanes.
- It may only be installed by suitably trained personnel. Any legal regulations or regulations issued by authorities must be observed during assembly.
- The device may only be opened at the manufacturer's site.
- The device is not allowed to be disposed of as household refuse. All locally valid regulations and requirements must be observed.
- When calculating the required torque, the specifications supplied by the damper manufacturer's (cross-section, design, installation site), and the air flow conditions must be observed.

Technical Drawing

